

June 15, 2005

CITY OF LANSING
NOTICE TO BIDDERS

B/05/306

GALVANIZED PRE-FAB STAIRS (TEN SETS)

The City of Lansing officially distributes Purchasing documents from the Michigan Inter-governmental Trade Network (MITN) and the City of Lansing Purchasing Office. Copies obtained through any other source are not considered official copies. If you have obtained this document from a source other than the City of Lansing Purchasing Office or MITN, it is recommended that you obtain an official copy. You may obtain an official copy of all Requests for Bids, Quotes and Proposals, addenda and bid tabulations on the MITN Site at <http://www.govbids.com/scripts/mitn/public/home1.asp>

Sealed bids marked "**B/05/306, GALVANIZED PRE-FAB STAIRS (TEN SETS)**" will be accepted at the City of Lansing, Finance Department, Purchasing Section, 8th floor, City Hall, 124 W. Michigan Avenue, Lansing, Michigan 48933 until, but not later than 3:00 PM local time in effect July 26, 2005, at which time and place the bids will be publicly opened and read aloud.

Contractors shall attend a **MANDATORY walk-thru**. **Any general contractor who fails to attend this meeting will be disqualified from bidding this project. This meeting will begin at 8:30 A.M., local time in effect July 15, 2005, at the Wastewater Treatment Plant offices, 1625 Sunset Avenue.** Bidder's representative at the meeting shall be solely responsible for insuring the Bidder's name, complete address and phone number appearing clearly and correctly on the City's attendance roster. Any addendums sent out are based on the accuracy of this attendance roster. ***Vendors in attendance at this meeting shall be responsible for confirming the existence of any addenda prior to the bid opening.*** Any proposal received from a bidder whose name does not appear on the City's attendance roster may be declared non-responsive and their bid not opened.

Due to the increased number of phone inquiries, bid results will **only** be released via email, self-addressed stamped envelopes or MITN site referenced above.

The City reserves the right to accept any bid, to reject any or all bids and to make the award in the best interest of the City.

Any changes made to the bid specifications shall be made in the form of an Addenda prepared by the City of Lansing and mailed to each plan holder. ***Vendors in attendance at the mandatory walk-thru shall be responsible for confirming the existence of any addenda prior to the bid opening.*** All addenda shall become part of the Contract Document and all bidders shall be bound by such Addenda, whether or not received by the Bidder. All addenda received shall be listed on the outside of the bid envelope by number, and date received. Any proposal received without each addendum listed by number on the outside of the bid proposal envelope, will be declared a non-responsive bid.

The City strongly recommends that the bid package be picked up and reviewed PRIOR to the pre-bid meeting in order for the contractor's to be prepared to make comments or ask questions regarding concerns based on their review of that package.

MAJOR CONTRACT ITEMS INCLUDE: THE SELECTED VENDOR TO FURNISH TEN SETS OF GALVANIZED BAR GRATING STAIRS TO BE DELIVERED FULLY ASSEMBLED TO THE WASTEWATER TREATMENT PLANT (F.O.B.), 1625 SUNSET AVENUE, LANSING, MICHIGAN, AS PER ALL ATTACHED PLANS AND SPECIFICATIONS

SPECIAL NOTE: The City of Lansing's Code of Ordinances, Section 206.07 (b) allows for the removal of a vendor's name from our mailing list if they have not responded to our last two (2) bid requests. If you have not responded to our last two (2) invitations to bid, and we do not receive a response to this bid or a request from you to remain on our bidder's list, your name will be removed from our vendor's list.

If you have any questions please contact John Green, Senior Buyer, at (517) 483-4129. Technical questions should be directed to Scott Jezak, Wastewater Treatment Plant Maintenance Supervisor, at (517) 483-4408. The City of Lansing encourages bids from all vendors including MBE/WBE vendors.

Antonia M. Kraus C.P.M.
Business Services Manager

Attention Bidders

Effective June 21, 2002, the Mayor renewed the Executive Order creating a preference for Lansing based businesses. The Executive Order will be in effect until December 31, 2005.

Qualifications for Lansing Based Business status:

- 1) Pay City income taxes on Net Profits
- 2) Pay City property taxes on a plant or office and equipment used for the performance of the contract bid upon - or - other real or personal property in the City of Lansing equivalent in value to such plant or office and equipment for not less than one year prior to determination.

Preference Statement:

A Lansing based business that has been deemed responsive and responsible according to the requirements of the Purchasing Ordinance that is within 5% of the low bid will be given an opportunity to match the low bid amount to receive the contract. If there is more than one qualified, responsive and responsible Lansing based bidder, the first opportunity to match the low bid will go to the Lansing based firm with the lowest bid.

If the Lansing based business refuses to match the low bid, the contract will be awarded to the responsive and responsible low bidder.

Additional Information:

The full copy of the Executive Order is on file in the Purchasing Offices, the City Clerk's office or on the City of Lansing Purchasing Web site located at:

<http://finance.cityoflansingmi.com/purchasing>

Solicitation Number: B/05/306

Solicitation Name: **GALVANIZED PRE-FAB STAIRS (TEN SETS)**

The City of Lansing Purchasing Office is collecting information regarding the use of the MITN e-procurement system. We are also collecting demographic information regarding woman-owned, minority-owned and Lansing based business. This form will not be used during the evaluation of bids or proposals. You may return this sheet in your bid envelope or mail it back separately. Please, do not staple this to your bid document.

I. Where did your firm receive of this solicitation? Please check all that apply.

City of Lansing Purchasing Web Page <http://www.govbids.com/scripts/MITN/public/home1.asp>

City of Lansing Purchasing Office

Other, please list: _____

II. Demographic Information:

Is your firm located or have a business office within the corporate city limits of Lansing
yes _____ no _____

Is your firm owned (at least 51% ownership), operated and controlled by a member of the following minority groups? If so, please check all that apply:

African-American

Hispanic-American

Native-American (American Indian, Eskimo, Aleut, Native Hawaiian)

Asian-Pacific

Asian-Indian (India, Pakistan and Bangladesh)

Disabled-Owned

Is your firm owned (at least **51%** ownership), operated and controlled by a female: Yes _____ No _____

III. Company Information

Firm Name

Address (Street, City, State, ZIP)

Phone Number

Fax Number

Web Site Address

Contact Person

Thank you for your participation.

CITY OF LANSING
 FINANCE DEPARTMENT-PURCHASING SECTION
 8TH FLOOR CITY HALL
 124 W. MICHIGAN AVENUE
 LANSING, MICHIGAN 48933

THIS IS NOT AN ORDER

NOTE: If your bid/quotation is not returned and **completed** on this form, it may not be considered.
 Bid/quotation number must appear on outside of return envelope.

REQUEST FOR BID # B/05/306

FOR: GALVANIZED PRE-FAB STAIRS (TEN SETS)

DATE June 15, 2005

PUBLIC SERVICE DEPARTMENT/WWTP

SEALED BIDS DUE 3:00 PM, LOCAL TIME IN EFFECT JULY 26, 2005

Please furnish your bid for providing GALVANIZED PRE-FAB STAIRS (TEN SETS) for the following as per the following specifications:

ITEM	QTY	DESCRIPTION	LUMP SUM PRICE
A	1 LS	TEN SETS, PRE-ASSEMBLED GALVANIZED BAR GRATING STAIRS AS PER ALL CITY OF LANSING SPECIFICATIONS AS ATTACHED.	\$

NOTE: Any exception to specifications shall be listed on a separate sheet of paper and attached to this bid. If your bid is not returned on this form and/or this form is not completely filled out, your bid will be considered non-responsive. All sealed bids must be clearly marked with the bid number B/05/306 on the outside of sealed envelope(s).

OMISSIONS: The specifications are intended to include all work and materials necessary for completion of work. Any incidental item of material, labor or detail required for proper execution and specifications or both, but obviously required by governing codes, local regulations, trade practices, operational functions and good workmanship, shall be provided as a part of the contract work without extra charge, even though not specifically detailed or mentioned.

The City of Lansing is exempt from all state and federal taxes. Exemption certifications available upon request. The City reserves the right to accept any bid, to reject any or all bids and to make the award in the best interest of the City.

This project shall be completed ninety (90) calendar days from written Notice to Proceed.

FEDERAL I.D.# _____ COMPANY _____ SIGNATURE _____ TITLE _____ ADDRESS _____ CITY & STATE _____	TELEPHONE _____ F.O.B. _____ ROUTING: _____ TERMS: _____ DATE OF PROPOSAL: _____
---	--

NOTE: No quote tabulation will be mailed after the award of the quote unless by a respondent who submits a stamped, self-addressed envelope with their quote.

MICHIGAN CIVIL RIGHTS ACT

Contractor shall not discriminate in hiring or its terms and conditions of employment on the basis of race, religion, creed, nation origin, color, sex, marital status, age, height, or weight, nor on the basis of handicap except where the same is based on a bona fide job requirement. Neither shall Contractor discriminate in the sales of products or the rendering of services pursuant to this contract on the basis of any of those categories.

The City of Lansing is requesting bids to purchase Ten sets of galvanized bar grating stairs. A mandatory pre-bid meeting will be scheduled to answer any questions and to measure the existing concrete structures selected for replacement. At the closing bid due date all submittals for each set of individual stairs are to be in drawing form for review by the City of Lansing. Prior to awarding the bid, all additions and/or changes are to be resubmitted for final approval. Listed below are the general specifications, dimension table, drawings and shipping requirements.

Galvanized Bar Grating Specifications Job# Plant - 2005 General requirements and specifications.

- Reference drawings, location and dimension table for additional construction details.
- Tread type - Galvanized bar grating with abrasive 1" nosing.
- All materials to be galvanized unless noted otherwise in drawing.
- Must meet all Michigan General Safety Standards.
- Stairs to be shipped fully assembled, except when the shipping weight per unit exceeds #3,500.
- All variances to the specifications must be listed along with submittals. Variances are then reviewed and the City of Lansing may accept or decline any proposed changes.
- Railing is to be included on both sides of all stairways over three feet in height.
- There will be a tour after the pre-bid meeting to confirm all dimensions, discuss options and to insure all the suppliers present obtain equal information.

****Note** - The above Galvanized bar grating stairs are expected to be meet all Michigan Industrial Safety Standards, written specifications, and constructed as approved in the final submittal drawings. The City of Lansing will not accept damaged items, or items found not to be constructed per submittal drawings

Shipping requirements

- All shipping charges to be included in the bid price.
- Shipping address is City of Lansing Wastewater Treatment
1625 Sunset Ave. Lansing, Mi 48917
- Shipping /receiving at Lansing Wastewater – Monday – Friday
7:00 am – 3:00 PM .
- Stairs are to be fully assembled and clearly marked for location as referenced within the attached table.
- Stairs exceeding #3,500 may be partially disassembled to keep the weight below #3,500.
- Flatbed style trailer with removable sides for shipping, no enclosed trailers.
- Two working days notification prior to shipping.

Galvanized Bar Grating Stairway Dimensions

Location	A	B	C	D	E	F	G	H
South P. Sec. Control North East	66 in.	50 in.	7 in.	Minimum 8 inches 1-1/4" X 3/16"	69 in.	72 in.	1-1/2" Scheduled 40 Alum. Pipe	C10 x 8.4
South P. Sec. Control South East	66 in.	50 in.	7 in.	Minimum 8 inches 1-1/4" X 3/16"	69 in.	72 in.	1-1/2" Scheduled 40 Alum. Pipe	C10 x 8.4
South P. Blower South West	66 in.	50 in.	7 in.	Minimum 8 inches 1-1/4" X 3/16"	32 in.	36 in.	1-1/2" Scheduled 40 Alum. Pipe	C10 x 8.4
South P. Boiler West	65 in.	42 in.	7 in.	Minimum 8 inches 1-1/4" X 3/16"	32 in.	36 in.	1-1/2" Scheduled 40 Alum. Pipe	C10 x 8.4
South P. Equalization North East	70 in.	50 in.	7 in.	Minimum 8 inches 1-1/4" X 3/16"	58 in.	65 in.	1-1/2" Scheduled 40 Alum. Pipe	C10 x 8.4
South P. Equalization South East	70 in.	50 in.	7 in.	Minimum 8 inches 1-1/4" X 3/16"	58 in.	65 in.	1-1/2" Scheduled 40 Alum. Pipe	C10 x 8.4
South P. Aeration #22	17 in.	17 in.	7 in.	Minimum 8 inches 1-1/4" X 3/16"	52 in.	60 in.	1-1/2" Scheduled 40 Alum. Pipe	C10 x 8.4
South P. Aeration #22	28 in.	23 in.	7 in.	Minimum 8 inches 1-1/4" X 3/16"	52 in.	60 in.	1-1/2" Scheduled 40 Alum. Pipe	C10 x 8.4
South P. Aeration #22	39 in.	30 in.	7 in.	Minimum 8 inches 1-1/4" X 3/16"	52 in.	60 in.	1-1/2" Scheduled 40 Alum. Pipe	C10 x 8.4
North P. Shop/Break South East	50 in.	50 in.	7 in.	Minimum 8 inches 1-1/4" X 3/16"	45 in.	50 in.	1-1/2" Scheduled 40 Alum. Pipe	C10 x 8.4

(A) – Stairway Total Run Length.

(B) – Stairway Total Run Height.

(C) – Step Rise.

(D) - Step Run/Depth.

(E) – Bar Grating Dimensions (Stair Width.)

(F) – Total Stairway Width. (With Rail & Channel iron.)

(G)– Hand Railing.

(H) – Steel Stringer

Drawing Data

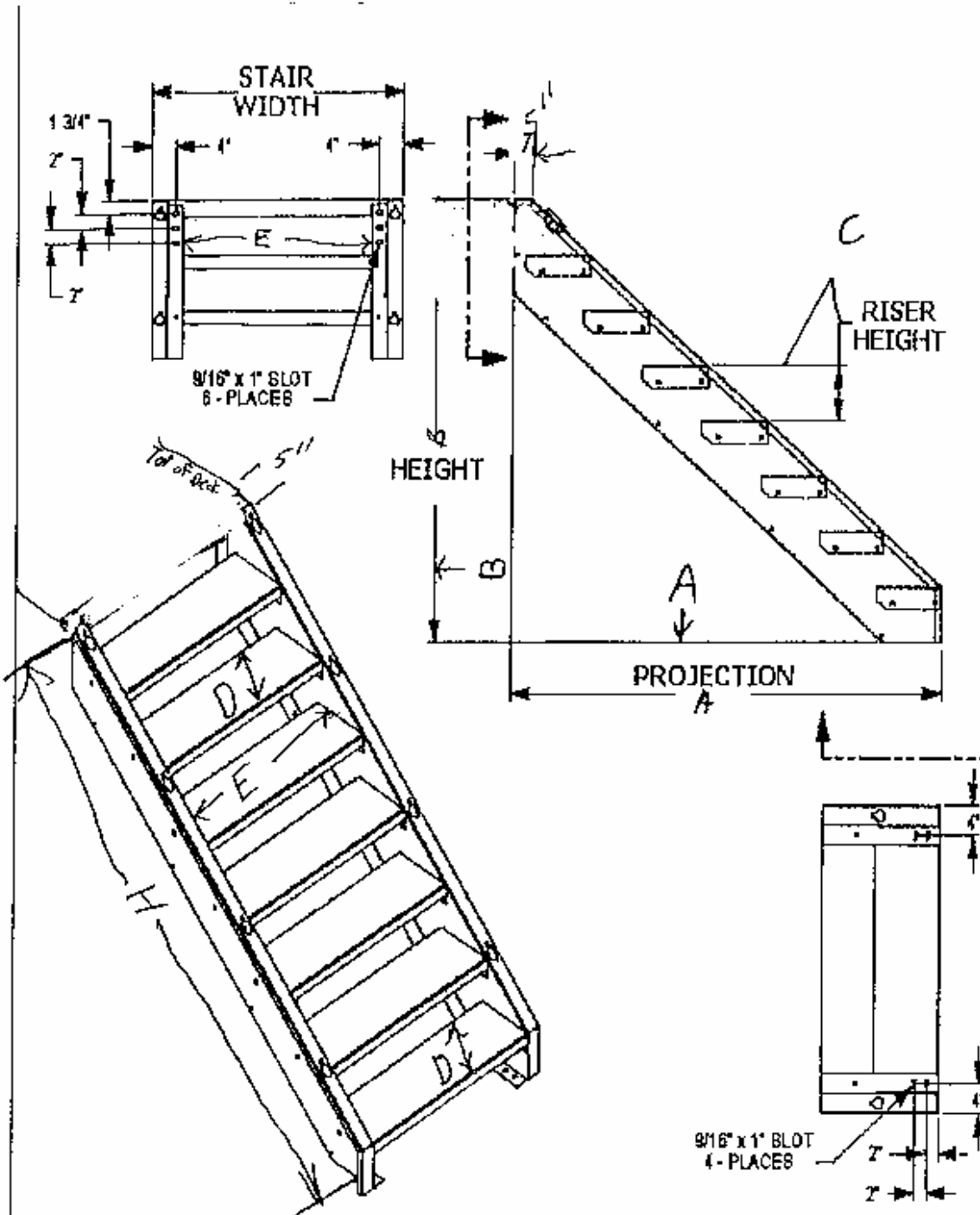

GRATING STAIR AT
CONCRETE SLAB

